



SOLUZIONE PER L'ASCIUGATURA - LINEA ES P-LINE  
DRYER SOLUTION - ES P-LINE SERIES

SCHEDA COMMERCIALE  
COMMERCIAL SHEET











**ESSICCATOI PROFESSIONAL DA 6 E 8 KG  
TUMBLE DRYER PROFESSIONAL FROM 6 AND 8 KG**



SCANSIONA PER ALTRE INFO  
SCAN FOR MORE INFO



VALORI PRODOTTO  
HIGHLIGHTS

-  10 programmi disponibili  
10 available drying programs
-  Macchina compatta adatta all'incasso domestico  
Compact machine suitable for domestic installation
-  Macchina sovrapponibile con Lavatrice P-LINE  
Stackable with P-LINE washing machine
-  Sistema di rotazione cesto BUTTERFLY  
BUTTERFLY drying system prevents the clothes from bundling and creasing
-  Arresto immediato del ciclo in caso di apertura porta  
Safety system stops cycle if the tumble dryer is opened during drying
-  Filtro di condensa e doppio filtro lanugine e polvere facilmente removibili  
The condenser is easy to remove and clean and Double lint filter, easy to clean
-  Motore senza spazzole per minore rumorosità e durata  
Robust brushless induction motor with one-way operation leads to longer lifetime, lower noise and faster drying
-  Due rulli di supporto cesto aggiuntivi per una migliore stabilità - anche in caso di carichi pesanti.  
Two additional supporting rolls for better stability - also for heavy loads
-  La versione con POMPA DI CALORE può essere installata anche in spazi piccoli, chiusi e poco ventilati.  
The heat pump dryers can be installed in rooms with a lower level of ventilation
-  Tutti i componenti superiori ai 50 gr sono riciclabili  
Each component over 50 gram is marked for recycling
-  Cesto, top e fronte in ACCIAIO INOX AISI 304  
Attractive stainless steel AISI 304 casing and wash drum

OPTIONAL / OPTIONS

- Basamento di rialzo h 300 mm
- Stainless steel base h 300 mm
- Gettoniera meccanica per versione self-service
- Mechanical coin box for self-service use
- Gettoniera elettronica per versione self-service
- Electronical coin box for self-service use



**DATI TECNICI / TECHNICAL DATA**
**ES 65**

 PEC - PEE  
PEHP

**ES 80**

 PEE  
PEHP

- Capacità 1:9 - 1:10 / Capacity 1:9 - 1:10	6,2 - 5,6 Kg (14 - 12 lb)	8,1 - 7,3 Kg (19 - 16 lb)
- Volume cesto / Drum volume	112 lt	145 lt
- Intensità sonora / Air sound intensity	66 dB (A)	66 dB (A)
- Dimensioni macchina : LxPxH / Machine dimensions WxDxH (100 mm = 3.93 inch.) PEC - PEE	595x585x845 mm	595x745x850 mm
- Dimensioni macchina : LxPxH / Machine dimension WxDxH (100 mm = 3.93 inch.) PEHP	595x745x845 mm	595x745x850 mm
- Peso netto / Net weight PEC - PEE	44 - 41 Kg (97 - 90 lb)	45 Kg (99 lb)
- Peso netto / Net weight PEHP	45 Kg (99 lb)	62 Kg (137 lb)
- Dimensioni imballo : LxPxH / Packing Dimension WxDxH (100 mm = 3.93 inch.)	640x660x920 mm	640x810x920 mm
- Peso lordo / Gross weight	50 Kg (110 lb)	50 - 64 Kg (110-141 lb)
- Volume imballo / Packaging volume	0,48 mc (16.9 ft³)	0,48 mc (16.9 ft³)
- Classe energetica / Energy class	A++	A++
- Potenza elettrica di installazione / Installation electric power PEC - PEE	2,3 kW	2,25 kW
- Potenza elettrica di installazione / Installation electric power PEHP	0,8 kW	0,9 kW
- 1ph230V 50 Hz / 3ph400V + N 50 Hz	16 A / 10 A A	16 A / 10 A A
- Grado di protezione IP / IP Class of protection code	X4	X4
- Lunghezza cavo alimentazione / Supply cable length	2100 mm (82.7 inch.)	2100 mm (82.7 inch.)
- Macchine imballate STD per container 20' / STD. packed machines in to 20' container	54 pz. sovrapposte	50 pz. stackable
- Macchine imballate STD per container 40' / STD. packed machines in to 40' container	108 pz. sovrapposte	104 pz. stackable

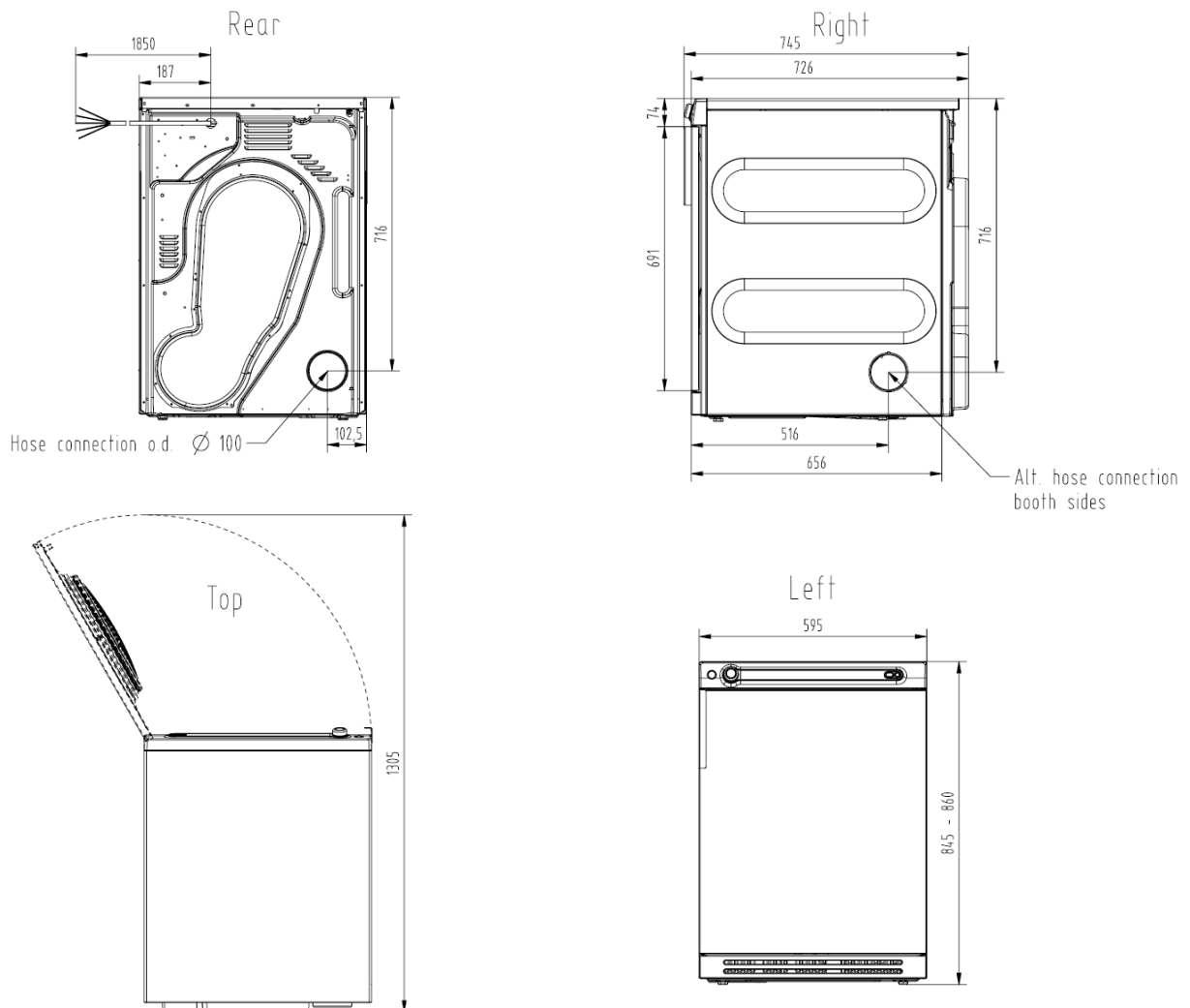

100 mm = 3.93 inch. - fattore di conversione 1 / 25,4 \ factor conversion 1 / 25,4